



Canadian Distributor  
POWER PLANT SUPPLY CO  
<http://www.powercanadasolutions.com/heatshrink.html>  
ONTARIO/Western Canada QUEBEC: 416 752 3339  
ATLANTIC/North & East Quebec: 902 435 9899 / 709 747 7650



# Water Infiltration Sealing System Power Plant Supply Co distributor



The Riser-Wrap® seal is a two-layer system designed for corrosion and sealing protection on pipelines and encapsulating manholes to seal joints against ground water infiltration.

The first layer is a visco-elastic adhesive liquid sealant covered by a heat shrink sleeve. The heat shrink is a thick-walled .098" (2.5mm), cross-linked, high density polyethylene membrane.

**Applications:**

- Manhole Encapsulation/Sealing
- Pipelines
- Repair and Rehabilitation
- Step-Down Joints
- Square/Rectangular Vaults
- Septic Tanks/Vaults



**Riser-Wrap® Square Vault Application**

**Riser-Wrap® Sealing System Features and Benefits:**

**Low Preheat Requirements**

- Preheat required only to remove the moisture from the surface and for fast/easy installation.

**Offers Permanent Heat Change Indicators**

- Permanent Heat Indicator ensures that the correct application of heat has been applied to the entire heat shrink sleeve.
- Installation is fully inspectable at any time after the installation.

**High Modulus of Elasticity Backing**

- Accommodates ground movement.

**High Impact and Penetration Resistance**

- Toughness to resist soil stress.

**High Shrink Force**

- Optimizes flow and fill of visco-elastic adhesive sealant.
- Seals against ground water infiltration.

**Impermeable**

- Provides corrosion protection.
- Extends structure life.

**No Special Tools**

- Quick & easy installation.

**Sizing Calculation Program**

- On-line at [www.riserwrap.com](http://www.riserwrap.com).

**Riser-Wrap® Sealing System Properties:**

**Adhesive**

	ASTM Test	TEST RESULTS	
<b>Softening Point</b>	ASTM E-28	205°C	400°F
<b>Lap Shear</b>	ASTM D-1002	12N/cm <sup>2</sup>	18psi
<b>Backing</b>			
<b>Tensile Strength</b>	ASTM D-638	22mPa	3,300psi
<b>Elongation</b>	ASTM D-638	650%	
<b>Hardness, Shore D</b>	ASTM D-224	58 Shore D	
<b>Shrink Force</b>	ASTM D-638	26N/cm <sup>2</sup>	38psi
<b>Dielectric Strength</b>	ASTM D-149	20KV/mm	500KV/in.
<b>Sleeve</b>			
<b>Peel Strength</b>	ASTM D 1000	20N/cm	11lb/in.
<b>Water Absorption</b>	ASTM D-570	0.05%	
<b>Low Temp. Flexibility</b>	ASTM D-2671	-40°C	-40°F
<b>Penetration Resistance</b>	ASTM G-17	PASS	

**Riser-Wrap® Heat Shrink System - Typical Specification**

**1.0 Scope**

Apply PSI Riser-Wrap® heat shrinkable sleeve on exterior concrete manholes or other structures at locations indicated by the Engineer to protect manhole and reduce infiltration or ingress of water and other contaminants. The sleeve shall be applied over a cleaned, primed surface. The Riser-Wrap® system shall be as manufactured by Pipeline Seal and Insulator, Inc, Houston, Texas

**2.0 Sleeve - High Density Polyethylene Membrane.**

The heat shrinkable sleeve shall consist of an 11" or 17" wide wrap-around, 2.5mm thick, cross-linked high density polyethylene membrane complete with a mastic. Peel Strength shall be a minimum of 11 lb./in. per ASTM D 1000. Tensile Strength shall be 3,300 psi minimum per ASTM D-638. Mastic softening point shall meet or exceed 400°F in accordance with ASTM E-28. Sleeve shall incorporate permanent heat indicators, to assure proper heating.

**3.0 Joiner-Strip**

The material to close the sleeve shall consist of a high density polyethylene fiber reinforced material to assure sleeve pulls tight. Lap Shear on assembled system shall exceed 18psi per ASTM D-1002.

**4.0 Primer**

Primer shall be a Polyken 1027 or 1039 primer. Primer shall be black in color and applied at a rate of approximately 2 – 3 mills. Must be able to dry with-in one hour.



**Riser-Wrap® Vacuum Test**

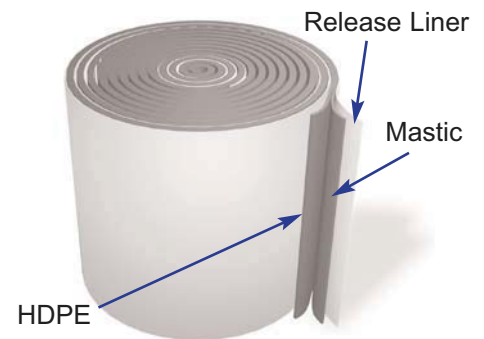





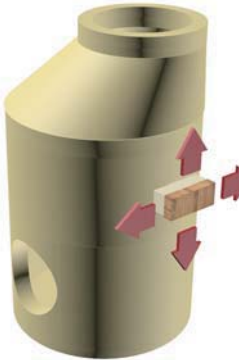
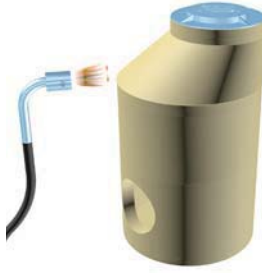
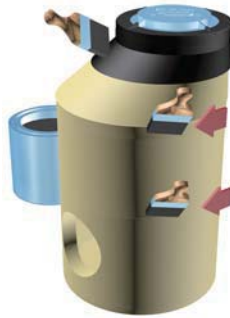

Available in 17", 11" and 5.5" widths x 50 ft. rolls.

Installation Video and Complete Installation Guideline available to view online at [www.riserwrap.com](http://www.riserwrap.com)

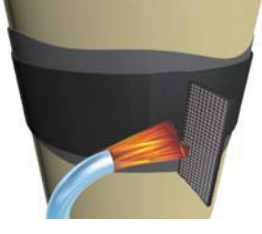

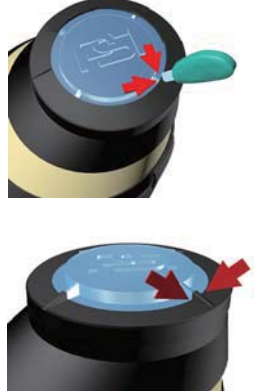
### Basic Installation Guidelines

 <p><b>1.</b> Clean all exterior surfaces of the manhole with a brush or broom to remove any loose cement, dust or small rock particles.</p>	 <p><b>2.</b> Preheat manhole surface. The function of preheating is to remove excess moisture.</p>	 <p><b>3.</b> Apply Polyken #1027 or #1039 liquid adhesive primers to the entire exposed concrete application surface.</p>	 <p><b>4.</b> Remove 8" (20cm) of release backing and position exposed surface on cleaned and primed seam area. Expose 8" (20cm) sections at a time as you wrap the sleeve material around the entire circumference of the manhole.</p>	 <p><b>5.</b> Using a small amount of flame, heat the adhesive side (<b>Fiber Reinforced</b>) of the adhesive joiner-strip. Center the strip vertically over the overlap sleeve edge, hold in place and apply small amount of heat to the face of the joiner-strip (<b>Black Side</b>).</p>
 <p><b>6.</b> Using a moderate to high flame, begin heating Riser-Wrap® sleeve material from the bottom edge moving around the structure in one direction.</p>	 <p><b>7.</b> Carefully cut the Riser-Wrap® sleeve when applying over cast iron manhole gussets. Gently mold with heat the sleeve around gussets with roller/gloved hand.</p>	<p><b>8. Inspection</b> Visually inspect the installed sleeve to make sure the sleeve is in full contact with the cone section and manhole frame. Also verify that the adhesive flows beyond the sleeve edges and that no cracks or holes exist in the sleeve backing.</p>	<p><b>9. Backfilling Guidelines</b> After shrinking is complete, allow the sleeve to cool prior to backfilling. Water quenching of the sleeve is acceptable to facilitate immediate backfilling. To prevent damage to the sleeve, use selected backfill material (no sharp stones or large particles) otherwise an extruded polyethylene mesh or other suitable shield should be used.</p>	<p><b>Optional: Gusset Installation</b> Use small sections (4" to 6" strips) of filler cord and mold around gussets.</p> 

**Primer Not Needed for Asphalt or Bituminous Coated Concrete.**  
Apply Riser-Wrap® directly on the coated surface. Do not apply Polyken 1027 or 1039 primer over asphalt. Apply primer to bare surfaces only.

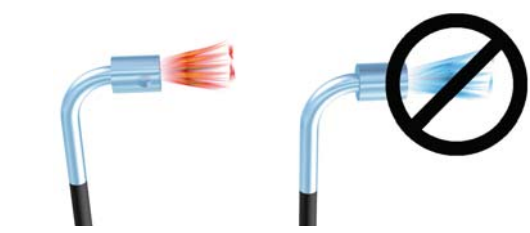

Use yellow/orange flame when heating RW material. Blue flame will overheat material.

**Note:** Detailed/Complete Installation Guidelines packaged with boxed Riser-Wrap® material.



**Tools Required for Installation**

1. Approved torch assembly, regulator and Propane bottle. (BN-80 head suggested)
2. Tape Measure. (16')
3. Heavy Duty Knife.

4. Paint Brush or Paint Roller.
5. Marking Pens. (Sharpie)
6. Heat Resistant Gloves or Welder's Gloves.
7. Approved surface rolling device. (4" roller)
8. Wire brush or broom.
9. Approved solvent or cleaner & rags.
10. Crescent Wrench
11. Safety Glasses or Goggles

## Ordering:

Riser-Wrap heat shrink sleeves can be supplied in 5.5" (140mm), 11" (280mm) or 17" (432mm) widths and shipped in 50 ft. rolls. Primer and joiner-strips required.

### To determine the amount of RW material required:

**Sleeve Width:** Measure width of area to cover. Add about 3" above and below seal area.

**Select 17", 11" or 5.5" widths.**

**Note:** Select sleeve width that will overlap by 2" (50mm) on each side of the overlap joint. Figure 10% shrinkage during installation of sleeve width when calculating the minimum sleeve width.

**Sleeve Length:** Measure **Circumference** of pipes, cones, manhole frames/rings, concrete risers at the widest or largest point. {When measuring use the following formula}.

**Circumference + 6" = RW Length**

**Example:**      **18" Dia. Grade Ring**  
Circumference = 56.52 - Round up to 57"  
57" + 6" = 63"

**USE:**            **RW 17" x 63" Sleeve**

### To determine the number of primer cans required.

Primer is supplied in 1 gallon cans, which covers 320 sq. ft. @ 2-3 mils brushed or rolled.

**Example:**       $\frac{63" (\text{Length}) \times 17" (\text{Width})}{144" / \text{sq. ft.}} = 7.4 \text{ sq. ft.}$

### To determine the amount of RW Joiner-Strips.

Order in 5.5", 11" or 17" for each RW application.

**1-RW-JS-17"**

**Visit [www.riserwrap.com](http://www.riserwrap.com) for on-line calculation program.**

## Storage & Safety Guidelines

To ensure maximum performance, store products in a dry, ventilated area. Keep products sealed in original cartons and avoid exposure to direct sunlight, rain, snow, dust or other adverse environmental elements. Avoid prolonged storage at temperatures above 130°F. (54°C.) or below -4°F. (-20°C.). Product installation should be done in accordance with local health and safety regulations.



Riser-Wrap® used to rehab. an existing manhole submerged in runoff water.



## Pipeline Seal and Insulator, Inc.

6525 Goforth Street, Houston, TX 77021 U.S.A.

T: 713-747-6948, F: 713-747-6029

Toll Free: 800-423-2410

[www.pipeline Seal.com](http://www.pipeline Seal.com), e-mail: [info@psipsi.com](mailto:info@psipsi.com)

[www.riserwrap.com](http://www.riserwrap.com)



Riser-Wrap® 11" Material

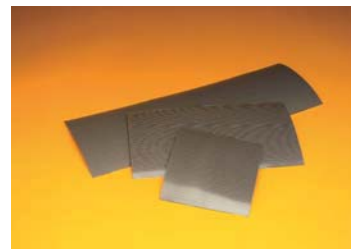

Joiner-Strips



Polyken Primer

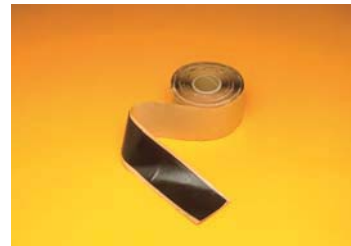

Filler Cord

## Warranty:

All products are warranted against failure caused by manufacturing defects for a period of one year. Any product found to be so defective and returned within one year from date of shipment will be replaced without charge. The above warranty is made in lieu of, and we disclaim, any and all other warranties, expressed or implied, including the warranties of merchantability and fitness for a particular purpose, and buyer agrees to accept the products without any such warranties. We hereby disclaim any obligation or liability for consequential damages, labor costs or any other claims or liabilities of any kind whatsoever.

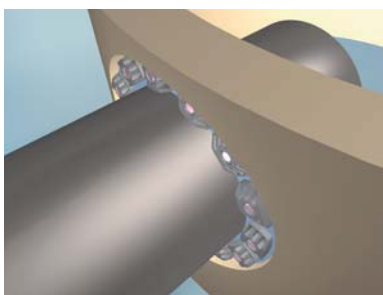

## The Complete Manhole Sealing System

**Link-Seal® Modular Seals in Combination with Riser-Wrap heat shrink sleeves.**

Create a Positive Hydrostatic Seal (20 psig, 40 feet head) in the annular space between Pipe and Pre-Cast Base. See Link-Seal® Engineering Manual for Link-Seal® modular seal selection when sealing pipe penetrating curved concrete surfaces.

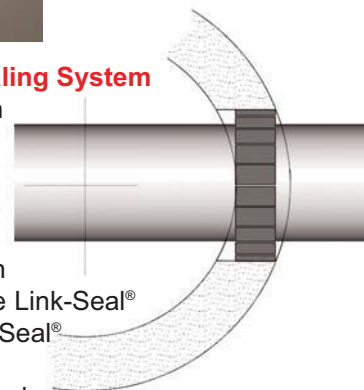

**Canadian Distributor  
POWER PLANT SUPPLY CO**

<http://www.powercanadasolutions.com/heatshrink.html>

**ONTARIO/Western Canada QUEBEC: 416 752 3339**

**ATLANTIC/North & East Quebec: 902 435 9899 / 709 747 7650**